

# Case Study Prüftechnik Condition Monitoring GmbH / WWK Insurance Group

Internationale Fachmesse  
für industrielle Instandhaltung

**M,O,C, München**  
**17.-19. Oktober 2006**

International Trade Fair for  
Industrial Maintenance

M,O,C,  
Messe München GmbH  
Lilienthalallee 40  
81823 München  
Germany

Telefon (+49 89) 3 23 53-189  
Telefax (+49 89) 3 23 53-197  
info@maintain-europe.com  
www.maintain-europe.com



## Climax Climate at WWK in Munich – Condition Monitoring Secures Operational Availability of Ventilation and Air-Conditioning Systems

### Category

1. Maintenance Services
2. Vibration-measuring Devices (offline, online)
3. Condition Monitoring Systems (CMS)

### Market Sector

Insurance Industry

### Brief Description

- Securing operational availability of machines and equipment for ventilation and air-conditioning by installation of a condition-monitoring-system.
- Online-monitoring of the complete ventilation and air-conditioning system of a large administrative building enabling the planning of maintenance processes.

### Task

Securing operational availability of machines and equipment for ventilation and air-conditioning for the main administrative building of a insurance company by employment of a round-the-clock condition monitoring systems providing the precondition for the planning of maintenance processes.

### Preparation

Since 1998 the management of WWK Insurance Group has been located in a modern administrative complex in the Mars street 37 in Munich. It comprises 16.300 m<sup>2</sup>. About 1.200 employees work there. A centralized air-conditioning and ventilation system constitutes the core aggregate of the facility. It provides for room conditioning throughout the administrative centre. The air-ventilation machines essentially consist of 2 supply-air axial-flow fans each providing an output of 140 KW and an air supply of 300.000 m<sup>3</sup>/h and 2 exhaust-air axial-flow fans each providing an output of 76 KW and an air-outflow of 160.000 m<sup>3</sup>/h. A complete standstill of the ventilation system, which came with a total machine damage, had in the past created havoc, even though the initially unidentified damage had been marginal. Necessary spare parts procurement and elaborate repairs of ventilation equipment had taken 6 months. This experience prompted WWK to look for a remedy to the problem, particularly for monitoring vibrations and bearings of the respective ventilation machines. After examination of the job profile by a team from Prüftechnik Condition Monitoring GmbH, WWK was submitted a proposal how to implement the necessary measures.

### Implementation

*Even though WWK Insurance Group is actually not a manufacturing business, the availability of technical equipment and installations are highly important to ensure the employees' productivity. To avoid unplanned downtimes of the ventilation system, WWK commissioned Prüftechnik Condition Monitoring GmbH with the installation of a condition monitoring system of the type VIBRONET SIGNALMASTER:*

Condition monitoring is an early warning system to unveil the beginning of deteriorating processes to plan and initiate maintenance and repair services at an early stage, reducing sudden downtimes to a minimum. One of the first steps is to attach so called velocity sensors at selected measuring locations on the machine (see picture 2). Detected "raw signals" derived from acceleration and vibration velocity are send to VIBRONET Signal Master central computing unit. Depending on the task the "raw signals" are converted to gain certain machine parameters.

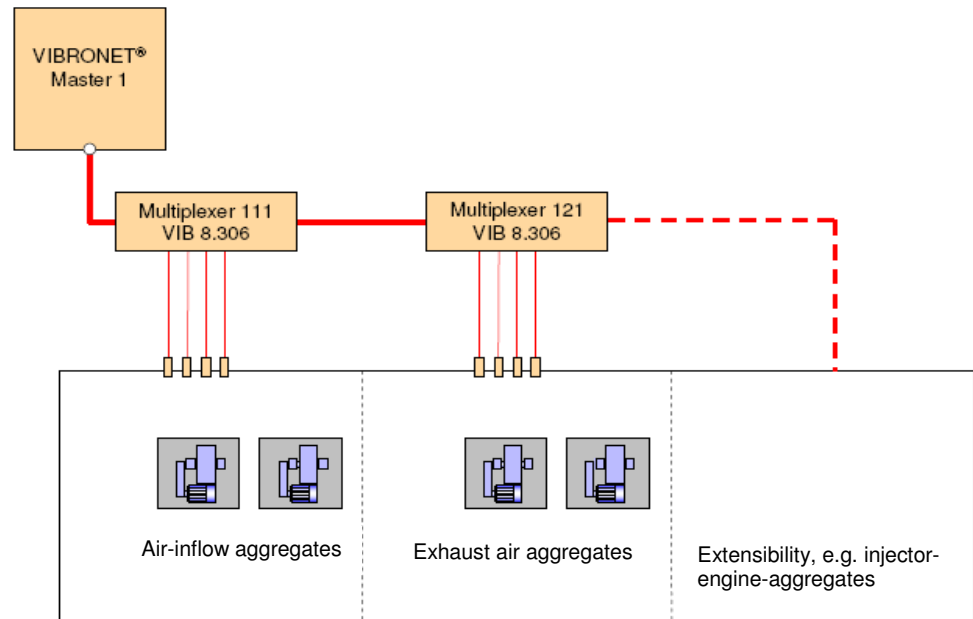

**Picture 1: Diagram of VIBRONET Signalmaster monitoring system**

Essential data for the online system employed at WWK is as follows:

- Online-Monitoring of 2 air-supply and 2 exhaust ventilators
- 8 vibration acceleration locations (vibrations & bearings surveillance)
- 16 status messengers (warnings/alarm) – to be handed over to existing facility engineering units
- 1 Signalmaster unit
- 2 VIBRONET Multiplexers

The Signalmaster unit works through a TCP/IP-protocol just like a “standard web participant” providing all measurement data. Visualisation and evaluation of data is realized through a HTML interface, which can be conditioned to the customer’s needs and is operated by a standard browser (e.g. Internet Explorer) supplied with any standard desk top computer. Comprehensive tools and utilities are furnished for an unerring status conditioning diagnosis regarding the equipment being monitored. This includes an external access if required for analysis by an external expert without creating additional costs by travel and on site presence. On top of this,

PRÜFTECHNIK offers contracts for online system maintenance.



**Picture 2: Industrial accelerometers attached to the bearing plate of the air propulsion motor**

As shown in picture 1 the VIBRONET-Signalmaster is connected in-line to all VIBRONET-Multiplexers through a string circuit. This wiring concept is rather beneficial with regard to investment budgets. To keep costs for wiring between Multiplexer and machine respectively measuring location as low as possible, these are installed next to the aggregates as close as possible. As it is the average length of these circuits is 10 metres between Multiplexer and velocity sensors. Detected “raw signals”

coming from these sensors constitute the basis for all following analysis steps. All relevant methods such as smooth-running properties (in accordance to DIN 10816-3) of the vibration velocity up to complex rolling contact bearing analysis through the so called envelope curve procedure are serviced by industrial accelerometers. Other parameters relevant to the operational process, e.g. temperature, pressure, revolutions or air quantity, are measured by the Multiplexers afield or are forwarded directly as process parameters to the Signalmaster.

Velocity data can fluctuate due to operations. These fluctuations are automatically accounted for in the Signalmaster by balancing them with pertinent process parameters. The acquired data is thus standardized and becomes feasible for evaluation and diagnosis. All monitored measuring quantities are provided with certain warning and alarm margins. Whenever these limits are reached the VIBRONET-Signalmaster sends specific alarm signals to the master control station through digital alert outlets.

The online system thus enables a consistent monitoring of machine operations. This early warning system permits detection of damages at a stage where costly machine repairs may be avoided. Unscheduled downtimes and loss of production is therefore something of the past.

- |                           |   |
|---------------------------|---|
| <b>Customer's Benefit</b> | <ul style="list-style-type: none"> <li>➤ Sustainable cost savings due to secure planning of maintenance and repair through employment of machine surveillance systems made by Prüftechnik Condition Monitoring GmbH.</li> <li>➤ Avoidance of work place impairment and decrease in productivity.</li> </ul> |
|---------------------------|---|

### Ordering Party

**WWK Insurance Group** is an independent, high-growth and strongly based financial services company. Within the life insurance sector, WWK belongs to the leading insurance companies in Germany. WWK is also successfully committed to personal and property insurance. WWK Insurance Group (amongst others the WWK Lebensversicherung a.G., WWK Allgemeine Versicherung AG, WWK Pensionsfonds AG) comprises a network of more than 10.000 sales representatives and round about one million clients. At the end of 2005 WWK Lebensversicherung a.G. (life insurance subsidiary) managed more than € 32 billion of insurance assets.

Internet: <http://www.wwk.de>

### Contractor

**Prüftechnik Condition Monitoring GmbH**, founded 1972, is a subsidiary of Prüftechnik Group, a specialist for maintenance technologies. As a leading maintenance technology company, Prüftechnik pioneered laser shaft alignment and offers products and services in alignment, condition monitoring and non-destructive testing. With subsidiaries and distributors in more than 70 countries the company serves manufacturing enterprises around the world.

Internet: <http://www.pruftechnik.com>

**Contact:** Michael Stolze, Sales & Marketing Manager  
 PRÜFTECHNIK Condition Monitoring GmbH, Oskar-Messter-Straße 19-21  
 D-85737 Ismaning  
 Tel.: (+49 89) 99616-110  
 Fax: (+49 89) 99616-184  
 E-mail: michael.stolze@pruftechnik.com

### Maintain 2006

The 2<sup>nd</sup> International Trade Fair for Industrial Maintenance will be staged from October 17th to 19th, 2006 at the M,O,C, trade fair centre in Munich. As MAINTAIN is the only specialized international trade fair for industrial maintenance in the world, it gives visitors a look at the latest trends in all sectors and furnishes them with information about state-of-the-art solutions that can be used to repair, maintain, inspect and improve their production facilities. For decision-makers and experts, that makes it the most important business gathering that deals with all aspects of industrial maintenance. Special fora on maintenance as a core factor for production and up-to-date information on MAINTAIN's web pages add to the event itself.

**Contact:** Sonja Kreitmeier, Public Relations Manager Maintain  
 Messe München GmbH, Messagelaende, 81823 Munich  
 Tel.: (+49 89) 949-20717, Fax: (+49 89) 949-9720717  
 E-mail: sonja.kreitmeier@messe-muenchen.de  
 Internet: <http://www.maintain-europe.com>